

SEM710 USER GUIDE

HEAD MOUNTED TRANSMITTER
 UNIVERSAL TEMPERATURE INPUT
 TWO WIRE (4 to 20) mA OUTPUT WITH
 DISPLAY

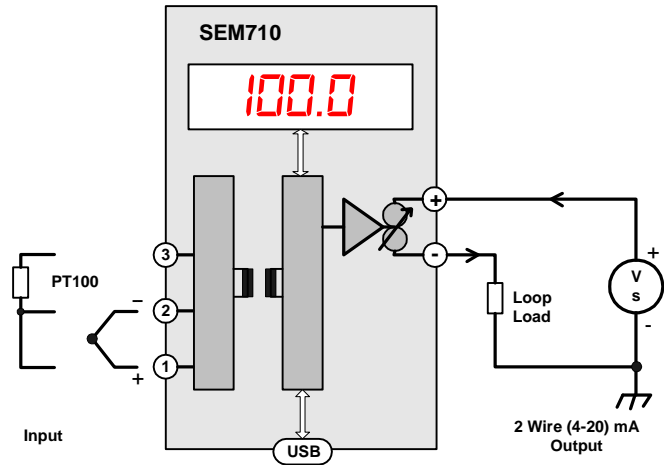

Important - Please read this document before any installing.



Every effort has been taken to ensure the accuracy of this document, however we do not accept responsibility for damage, injury, loss or expense resulting from errors and omissions, and we reserve the right of amendment without notice.



IMPORTANT - CE & SAFETY REQUIREMENTS

Product must be mounted, inside a suitable enclosure providing environmental protection to IP65 or greater.

To maintain CE EMC requirements, input wires must be less than 3 metres.

The product contains no serviceable parts, or internal adjustments. no attempt must be made to repair this product. Faulty units must be returned to supplier for repair.

This product must be installed by a qualified person. All electrical wiring must be carried out in accordance with the appropriate regulations for the place of installation.

Before attempting any electrical connection work, please ensure all supplies are switched off.

ABSOLUTE MAXIMUM CONDITIONS (To exceed may cause damage to the unit):-

Supply Voltage	± 30 V dc (Protected for over voltage and reverse connection)
Current with over voltage	± 200 mA
Input Voltage	± 5 V between any terminals
Ambient	Temperature (-40 to 85) °C Humidity (10 to 95) % RH (Non condensing)

PRODUCT SPECIFICATION

Please refer to the product data sheet for full specification, available to download at www.status.co.uk.

RECEIVE AND UNPACKING

Please inspect the packaging and instrument thoroughly for any signs of transit damage. If the instrument has been damaged, please notify your supplier immediately.

CONFIGURATION



IMPORTANT The SEM710 can be configured whilst connected and powered, but a portable battery powered computer must be used to avoid the effects of ground loops.

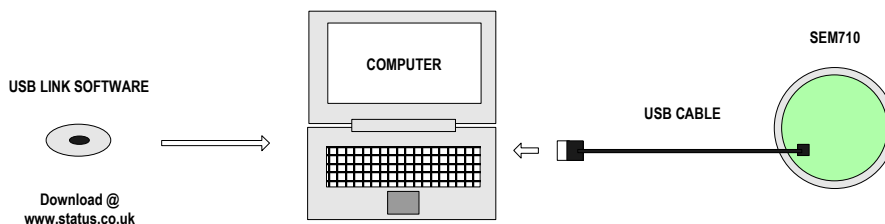

The following parameter can be configured by simply entering as prompted by the software package.

- Input type (K, J, E, N, T, R, S, PT100)
- Low range
- High range
- Units (°C, °F)
- Burnout (direction of output current on sensor burnout)
- User Trim (ON / OFF) [option to lock out trim function]
- Display mode Input (°C / °F) or Output mA

Factory default:

Input type	= P
Low Range	= 0
High Range	= 100
Units	= °C
Burnout	= UPSCALE
User Trim	= ON
Display	= °C

MECHANICAL INSTALLATION

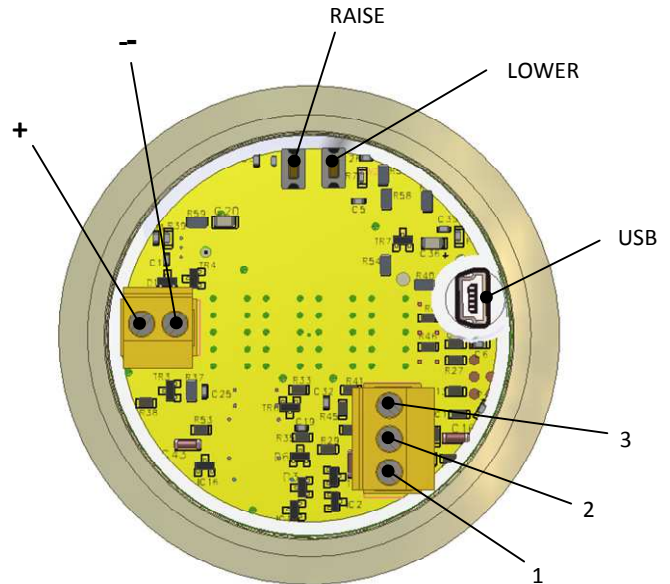

ELECTRICAL INSTALLATION



TURN OFF SUPPLY BEFORE WORKING ON ANY ELECTRICAL CONNECTION



Screened Cable



Screened TC Compensation Cable



Twisted Pair

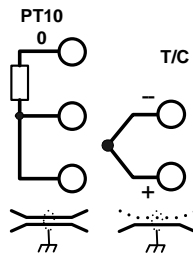
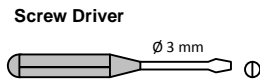

INPUT CONNECTION

For cable lengths < 3 Metres screen or twisted pair is not required
 For cable length > 3 Metres and < 30 Metres screen or twisted pair is required
 Cable lengths > 30 Metres are not recommended
 PT 100 Inputs of all three wires must be equal length (resistance).
 T/C Inputs must use the correct compensation cable

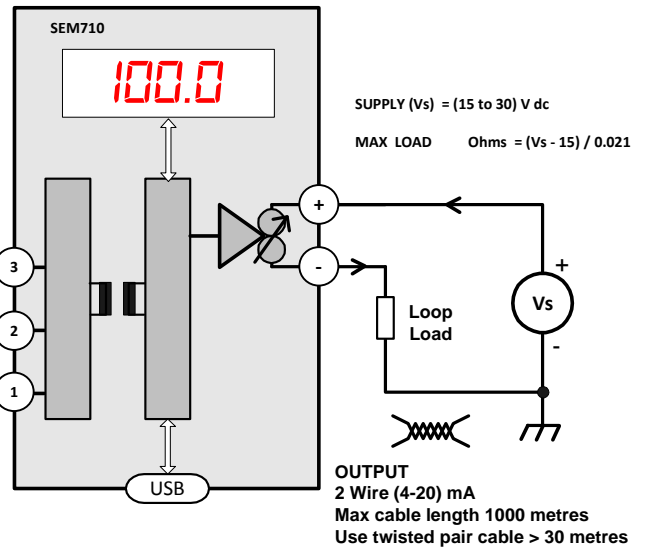

USER TRIM

User trim function allows manual adjustment of the output current, this is useful for minor calibration adjustment or trimming out any sensor error, ± 5% of range adjustment is available at both offset and span. Raise and lower buttons are provided on the back of the transmitter.

The transmitter will automatically detect the correct trim point (offset or span) based on the output current drive. Offset will be trimmed when the current is between (3.8 to 6) mA, span when the current is between (18 to 22) mA. No trim action occurs at any other current.

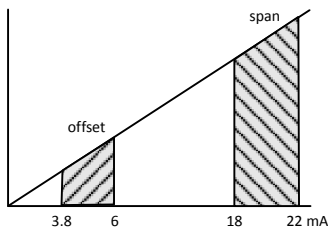

DISPLAY

If the input falls outside the ranged output the SEM710 will enter burnout condition on the output, but will continue to display the temperature. The SEM710 will indicate this by alternating the display to show 'OuER' or 'uND' depending on the burnout direction by the input reading.

METHOD

1.0 Ensure the SEM710 is correctly configured. Connect transmitter to a suitable input simulator or sensor. Connect output to a 24V dc supply. Turn supply on, set input to either offset or span calibration point.

2.0 During normal operation the SEM710 Display reading is calculated from the output current drive not directly from the input, therefore the display may be used to monitor trim adjustment. If required the output current may also be monitored with a current meter.

3.0 Enter trim menu by pressing "raise" button for > two seconds. When the trim menu is open the °C LED will flash :-
 °C LED will indicate Trim action
 Offset: LED flashes slowly
 Span: LED flashes fast

4.0 Trim output current by pressing either the raise or lower button, single click to step advance, or press continuously to auto advance. The SEM710 unit will automatically detect the correct trim point.

5.0 Once trim is complete allow 30 seconds with no button press, the transmitter will time out and return to normal operation.

DISPLAY ERROR MESSAGES

ERR	Sensor or system error
. (decimal point)	Configuration powered by USB
105.0 ouer 105.0 . . .	Output over range (flashes actual I/P measurement then Error Message)
-0.5 undr -0.5 . . .	Output under range (flashes actual I/P measurement then Error Message)