

# SEM206TH USER GUIDE

SMART HEAD MOUNT THERMISTOR TRANSMITTER  
TWO WIRE (4 to 20) mA OUTPUT

**Important - Please read this document before installing.**

Every effort has been taken to ensure the accuracy of this document, however we do not accept responsibility for damage, injury, loss or expense resulting from errors and omissions, and we reserve the right of amendment without notice.

**IMPORTANT - CE & SAFETY REQUIREMENTS**

Product must be mounted inside a suitable enclosure providing environmental protection to IP65 or greater.  
To maintain CE EMC requirements, input wires must be less than 3 metres.  
The product contains no serviceable parts, or internal adjustments. No attempt must be made to repair this product. Faulty units must be returned to supplier for repair.  
This product must be installed by a qualified person. All electrical wiring must be carried out in accordance with the appropriate regulations for the place of installation.  
Before attempting any electrical connection work, please ensure all supplies are switched off.

ABSOLUTE MAXIMUM CONDITIONS (To exceed may cause damage to the unit).	
Supply Voltage	± 30 V dc (Protected for over-voltage and reverse connection)
Current with over-voltage	± 100 mA
Input Voltage	± 3 V between any terminals
Ambient	Temperature (-40 to 85) °C, Humidity (10 to 95) % RH (Non-condensing)

**Important - Please read this document before any installing.**

## 1-DESCRIPTION.

The device is an in-head transmitter that accepts thermistor temperature sensors and converts the sensor output over a configured range to a standard industrial (4 to 20) mA transmission signal. The output signal is linear to temperature. A variety of thermistor types are available when using USBSpeedLink configuration software. Please consult your supplier for custom thermistors. In addition to the PC configuration feature, simple push button operation allows the user to select the desired temperature range manually, by either simulating the thermistor temperature with a resistance box or setting the thermistor sensor to the required calibration point and pressing button to store at both 4 mA and 20 mA points.

Calibration set up may be saved as a file on the PC for later use. If required, the desired range can be specified at the time of order, removing the need for user configuration.

## 2-RECEIVING AND UNPACKING.

Please inspect the packaging and instrument thoroughly for any signs of transit damage. If the instrument has been damaged, please notify your supplier immediately.

## 3-SPECIFICATION.

Refer to data sheet for full specification.

Configuration	
Factory default	YSI 10KB (0 to 100) °C, upscale burnout, 0.0°C offset

## 4-INSTALLATION AND WIRING.

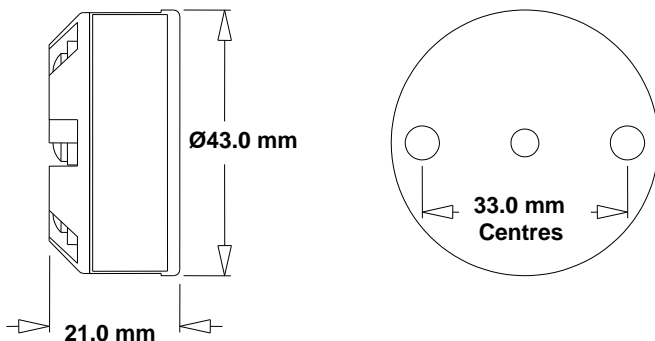

Mounting holes: two holes 5.5 mm diameter, 33 mm centres.

## 4.1-MECHANICAL.

The unit is mounted using two 5.5 mm holes, on standard 33 mm fixing centres and will fit a DIN standard termination head. The unit must be installed with adequate protection from moisture and corrosive atmospheres.

Care must be taken to ensure the unit is located so the ambient temperature does not exceed the specified operating temperature.

## 4.2-ELECTRICAL.

Electrical connections to the transmitter are made to the screw terminal provided on the top face. The transmitter is protected against reverse connection and over-voltage. If no sensor (input) connection is made, the transmitter will go into either up or down scale output current, depending on configuration setting.

TURN OFF SUPPLY BEFORE WORKING ON ANY ELECTRICAL CONNECTION

### Input sensor connections.

Sensor connections are as follows: to maintain BS EN61326 compliance, sensor wires must be less than 3 metres. All sensor connections must be isolated from ground.

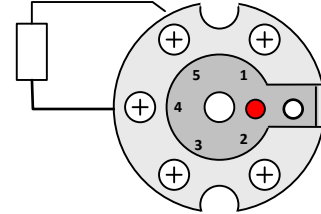

### (4 to 20) mA Loop connections.

Ensure all other aspects of the installation comply with the requirements of this document. To maintain CE compliance, the (4 to 20) mA current loop must be tied to a local earth at one point; this is normally at the power supply.

#### Wire (4 to 20) mA Loop

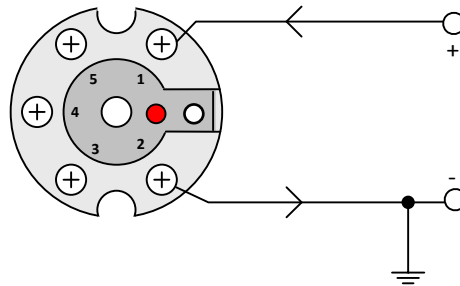

Use twisted pair or screened cables for cable lengths greater than 30 metres. Maximum cable length 1000 metres.

## 5-USER CONFIGURATION.

**IMPORTANT**

READ COMPLETE SECTION BEFORE ATTEMPTING CONFIGURATION.

### IMPORTANT

Do not attempt to configure the unit when connected to a loop supply.

A USB configuration module is required for connecting the unit to the PC. Refer to your supplier for details. The USB configuration module is required to change the sensor type.

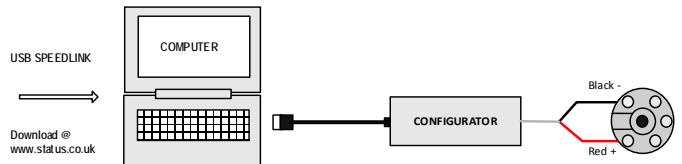

### Select sensor type

Configuration steps: change sensor	
1	Install the software and connect the USB configuration module to the PC.
2	Connect the configuration module to the device (removed from any loop supply).
3	Select the correct programming page in the software.
4	Read the unit configuration into the software.
5	Re-configure or adjust configuration options as required.
6	Send the new configuration to the unit.

Configuration options in software	
Thermistor type	From list
Low range 4 mA	Any °C/°F point within range
High range 20 mA	Any °C/°F point within range
Sensor fail	Burnout high or low

## 5~USER CONFIGURATION (continued).

### Range the input

Equipment:

Precision resistance box.

DC power supply (voltage between (10 to 30) V dc).

Screwdriver to operate push button.

Optional mA meter to monitor loop current.

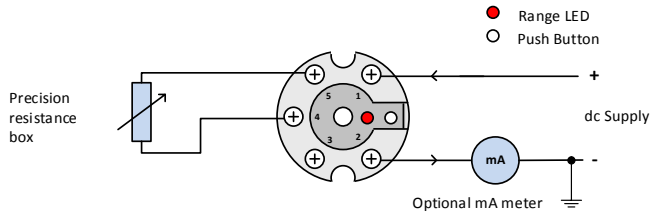

Refer to thermistor tables for correct sensor resistance

Configuration steps: range input with push buttons (optional)
Connect the circuit as shown above, mA meter is optional.
Set the precision resistance box representative value for low scale (4 mA out) sensor resistance. Allow ten seconds settling time. (Refer to thermistor tables for correct sensor resistance)
Press and hold push button (for about five seconds) until the range LED starts to flash. This indicates the new low range setting has been stored.
Set the precision resistance box representative value for high scale (20 mA out) sensor resistance.
Press and release push button to store new high range setting. The Range LED will flash at a faster rate to indicate storing new value.
Device returns to normal operation.



Status Instruments Ltd, Status Business Park, Gannaway Lane, Tewkesbury,  
Gloucestershire, UK, GL20 8FD

Web Page: [www.status.co.uk](http://www.status.co.uk), Email: [sales@status.co.uk](mailto:sales@status.co.uk)

Technical Support: [support@status.co.uk](mailto:support@status.co.uk)

Tel: +44 (0) 1684 296818, Fax: +44 (0) 1684 293746